

## General set up

- 1 Mount the fixture in the required position. The integral yoke can act as a floor stand or hanger.

### Important

- When suspended off ground, always use a safety wire rated to a minimum of 11 kg (25lbs) around the yoke.
- Do not position the fixture close to fog machines. The fog oil mist will be drawn in by the cooling fan and will short out important components. The warranty will be void for all fixtures returned in such a condition.

- 2 Where external control is to be used, connect a DMX lead (XLR 5-pin female) to the input socket at the rear of the fixture.
- 3 Where other fixtures are to be used in a control daisy-chain, connect a DMX lead (XLR 5-pin male) to the output socket at the rear of the fixture.

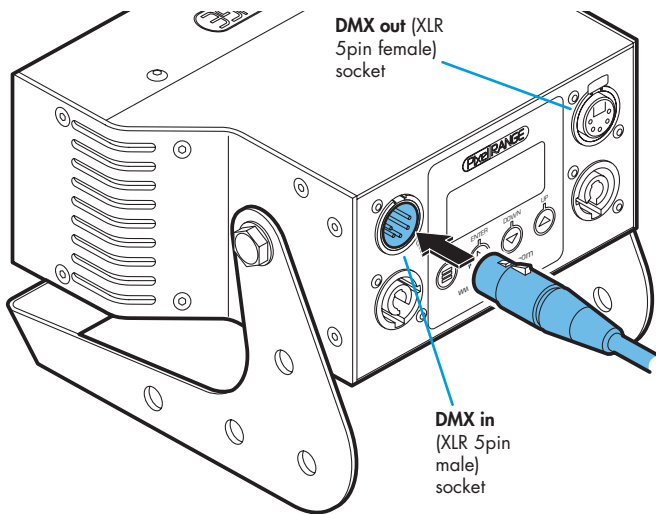

- 4 Connect power to the fixture using a Neutrik® PowerCon® connector. Insert the connector and twist it clockwise until it clicks into place.

### Important

- When daisy-chaining fixtures, do not exceed a total load of 3kW in a single daisy chain (subject to supply and cabling restrictions). Maximum power requirements per fixture: Micro Wash units - 66 watts. See also the 'Start up (peak)' note on page 4.

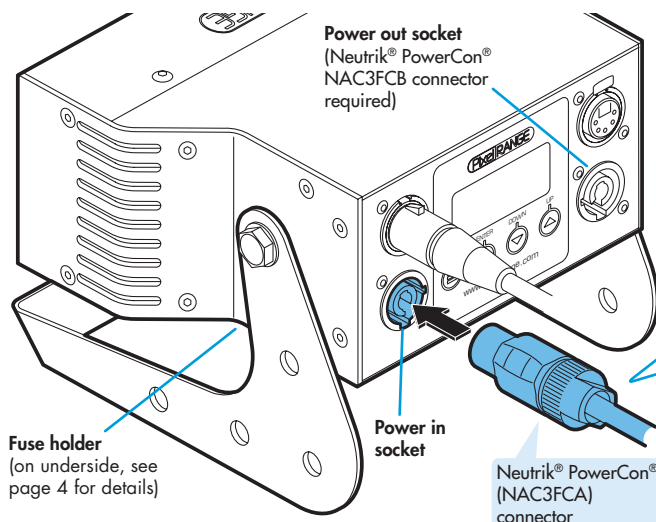

- 5 Use the control panel to access the internal menu and choose the appropriate operation mode and related settings (see over).

When suspended off ground, always use a safety wire rated to a minimum of 11 kg (25lbs) around the yoke

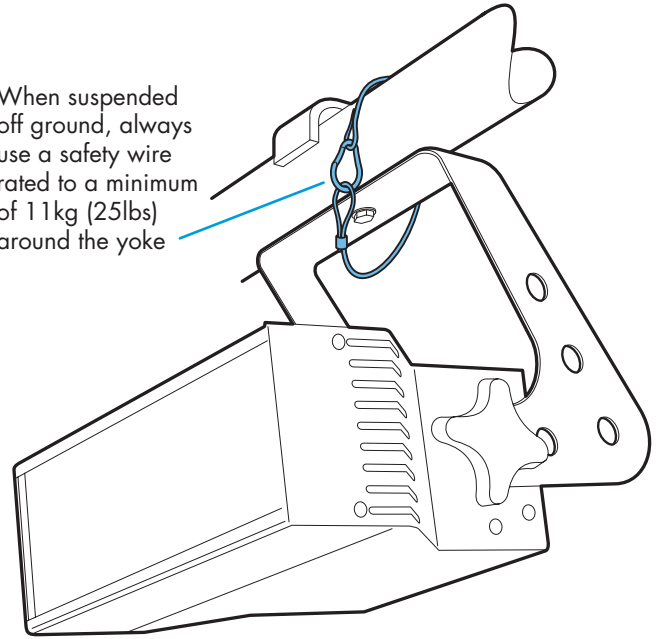

## Operation modes

The PixelLine Micro Wash fixture provides a range of operation modes. These are selected using the *ModE* section of the control menu:



Allows RGBA control via DMX input. Using the *RES* (resolution) option you can determine the number of DMX channels required: either 3 or 4 channels. In 3 channel mode, the red and amber channels are combined, whereas in 4 channel mode, the red and amber channels are controlled separately. Internal chase effects are not available within this mode.



Provides RGBA colour mixing independently of any external control. Use the internal control menu (*MANU* section) to select the required colour values.



Allows the display of the dual internal chase effects, independently of any external control. Use the internal control menu (*PROP* section) to select the required chase effects, speeds and cross fades.



Provides control of RGBA mixing and selection of the dual internal chase effects via DMX input. Requires 11 DMX channels.

PixelLine Micro fixture personalities are available for a variety of controllers. Please see [www.pixelrange.com](http://www.pixelrange.com) for details.

## Neutrik® PowerCon® (NAC3FCA) connector wiring

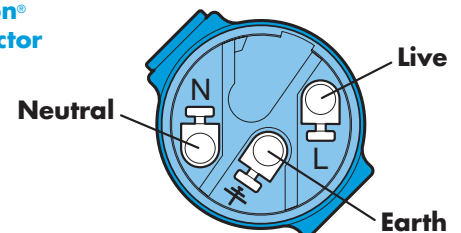

### Note

- To optionally clear all previous settings: At the rear panel, press the middle two buttons (▶ and ▼) while the DMX address is displayed (e.g. *ADD 1*, *ADD 2*, etc). The four digit display will show *FAC T* then *SET* to indicate that the fixture has been returned to its default condition.

## Menu operation

### General notes

- Ensure that only one DMX device in the chain is set as master (e.g. the lighting desk). This fixture is usually set to slave mode.
- This fixture is shipped with the DMX address set to 001.
- The four digit display can be set to switch off when not in use. To restore, press **MENU**. To alter this mode use: **PER5 > DISP**.



### Using the menu

- When not in the menu, the four digit display shows the current DMX address e.g. **Addr 1**. Some of the display's decimal points are used to indicate status (see below).
- Press **MENU** to enter the menu. The four digit display will show **Addr**.
- Use **DOWN** and **UP** to move between menu options (or to change a value within an option).
- Press **ENTER** to enter an option (or to fix a changed value within an option and return to the previous option level). *Note: If you do not press **ENTER** to fix a value, operation will revert to the previously set mode at the next power on.*
- Press **MENU** to exit from a menu option (and eventually exit the menu completely).

### Chase effects

This section describes each of the 31 internal chase effects that are selectable either via the control menu (**PER5 > [1/2] > EFEC**) or using DMX values sent from an external source. To use the internal effects, set the **ModE** option either to **EF 1** (to control effects via the menu) or **4+E** (to control effects externally via DMX). See page 4 for details about controlling effects on other fixtures via DMX without using a control desk.

DMX value	EFEC value	Chase effect description
0-7	00	Off
8-15	01	Rainbow chase forward
16-23	02	Rainbow chase reverse
24-31	03	10/90 duty cycle strobe white
32-39	04	10/90 duty cycle strobe white
40-47	05	10/90 duty cycle strobe white
48-55	06	50/50 duty cycle strobe white
56-63	07	50/50 duty cycle strobe red
64-71	08	50/50 duty cycle strobe blue
72-79	09	50/50 duty cycle strobe yellow
80-87	10	50/50 duty cycle strobe green
88-95	11	Pulse strobe white
96-103	12	Pulse strobe blue
104-111	13	Pulse strobe rainbow
112-119	14	Pulse strobe red/green/blue
120-127	15	Primary/secondary chase
128-135	16	Rainbow chase
136-143	17	Yellow/blue chase
144-151	18	Rainbow chase
152-159	19	Yellow/blue chase
160-167	20	Red/blue chase
168-175	21	Red/green chase
176-183	22	50/50 duty cycle fade red
184-191	23	50/50 duty cycle fade green
192-199	24	50/50 duty cycle fade blue
200-207	25	Static orange
208-215	26	Static yellow
216-223	27	Static light blue
224-231	28	Static purple
232-239	29	Static red
240-247	30	Static green
248-255	31	Static blue

### Channel layouts within operation modes

The table below shows how colour mixing, chase effects and master intensity controls are mapped to DMX channels for each mode. Mode **dm1** does not use chase effects. In all modes, the first channel of the fixture occurs at the DMX address selected using **Addr** and successive channels for the fixture follow from there.

*Note: The **PER5 > RES** option determines the number of channels required within **dm1** mode. There is a **16bT** option which does not operate, do not select this option.*

Channel	dm1 (RES=3Ch)	dm1 (RES=4Ch)	4+E (Wash)
1	Red	Red	Red
2	Green	Green	Green
3	Blue	Blue	Blue
4	Master intensity*	Amber	Amber
5	-	Master intensity*	[1] Effect
6	-	-	[1] Speed
7	-	-	[1] Xfade
8	-	-	[2] Effect
9	-	-	[2] Speed
10	-	-	[2] Xfade
11	-	-	Master int.

\* Master intensity for **dm1** mode is available only when the **PER5 > MINT** option is set to **off**.

### Display indications

Three of the display's decimal points are used to indicate the master/slave settings and also the presence of a DMX input signal, as shown below:



#### Master mode

On when the fixture is set within master mode. Use **PER5 > dATA** to change.

#### Slave mode

On when the fixture is set within slave mode. Use **PER5 > dATA** to change.

#### DMX input

Flashes when a valid DMX input signal is detected.

*Note: Ensure that only one DMX device in the chain is set as master (e.g. the lighting desk). This fixture is usually set to slave mode.*

## Menu contents

<b>Addr</b>	DMX	001	Sets the base DMX address from which the control channels will begin.	
<b>Info</b>	VER	CPU	V 101	Shows the main processor software revision. No changes are possible within this option.
		DISP	2 00	Shows the display controller software revision. No changes are possible within this option.
<b>PRoG</b>	C 1	EFEC	00	Selects the primary internal chase effect. See <i>Chase effects</i> for descriptions. Select <b>ModE</b> > <b>EF M</b> to show the selected chase.
		XFAd	000	Selects the cross fade speed between the steps of the selected C 1 chase effect.
		SPEd	000	Selects the speed of the selected C 1 chase effect.
		LEV L	255	Selects the master intensity level of chase effects C 1 and C 2.
	C 2	EFEC	00	Selects the secondary internal chase effect. See <i>Chase effects</i> for descriptions. Select <b>ModE</b> > <b>EF M</b> to show the selected chase.
		XFAd	000	Selects the cross fade speed between the steps of the selected C 2 chase effect.
		SPEd	000	Selects the speed of the selected C 2 chase effect.
	<b>MAN</b>	REd	255	Sets the red intensity. Select <b>ModE</b> > <b>MANU</b> (manual) to show the result.
		AMBR	255	Sets the amber intensity. Select <b>ModE</b> > <b>MANU</b> (manual) to show the result.
		BLUE	255	Sets the blue intensity. Select <b>ModE</b> > <b>MANU</b> (manual) to show the result.
GRN		255	Sets the green intensity. Select <b>ModE</b> > <b>MANU</b> (manual) to show the result.	
<b>PERS</b>	RES	4Ch	(Affects <b>dm11</b> mode only) Determines how DMX channels are assigned to colours. Options are 3Ch (red & amber combined), 4Ch & 16bt (do not use).	
	DATA	SLAV	Determines whether this fixture will act as a master controlling others. When controlled by DMX input, this fixture must be set to <b>SLAV</b> .	
	MINT	oFF	Affects <b>dm11</b> mode only. When set <b>oN</b> this enables the master intensity channel for <b>dm11</b> mode.	
	dINT	15	Determines the intensity of the four digit control panel display. Values range from 0 (dimtest) to 15 (brightest).	
	dISP	oN	When set to <b>oFF</b> , the control panel display will blank out shortly after the menu is exited. The DMX signal indications will remain active.	
<b>Mode</b>	DMX		RGB control using three DMX channels. <b>MINT</b> set to <b>oN</b> provides a master intensity. No chase effects are selectable.	
	MANU		Displays the resulting RGB levels that are set via the <b>MAN</b> section of the internal menu. External DMX control is not possible in this mode.	
	EF M		Displays the chase effect(s) determined within the <b>PRoG</b> section. External DMX control is not possible in this mode.	
	4+E		DMX Ch1 to 4: RGBA, Ch5 to 7: C 1 Effect, Speed & Xfade, Ch8 to 10: C 2 Effect, Speed & Xfade, Ch11: Master intensity.	

## Using master mode to drive other units

This unit can control any number of other Pixel Range fixtures via DMX links, without the need for a control desk.

- 1 Set this unit as **master** (`PER5 > dATA > MAST`) and ensure all others are set to **slave** (`PER5 > dATA > SLAV`). Connect all fixtures via DMX daisy-chain.
- 2 Set each slave to `ModE > dM`.
- 3 Set each slave DMX address (using `AddrP > dM`) according to the following:

18 cells are output in groups of 3 DMX channels to give RGB values per cell (54 channels in total). Set the address of each slave fixture according to which of the 18 cells you want them to appear within, or to begin with (for multi-cell fixtures): `PR01` for cell 1, `PR04` for cell 2, ... `PR52` for cell 18). Set RGBA slave fixtures to 3 channel mode (using `PER5 > RES > ECH`).

- 4 Set the master to `ModE > EF M` (the master unit's DMX address is ignored). On the master, choose the required effects to display and send to the slave fixtures using `PR06 > C 1` and `C 2`.

## Troubleshooting

### Fixture remains at blackout when illumination expected

- The display panel (or at least one of its decimal points) should be lit - if not, check the input power and fuse.
- If live DMX is connected, the right hand decimal point on the display should flash - if not, check the DMX cable and the desk output.
- Check that the selected `ModE` matches the desk personality being used.
- The master intensity channel for the current mode may be set at zero. For `dM` mode, check the setting of `PER5 > MINT`.
- Ensure that only one DMX device is set as master.
- Standalone chase effects: Effects programmed using `PR06 > C 1` and `C 2` but the fixture is not in `ModE > EF M` mode. Check also that `ModE > PR06 > LEVL` is not set at zero.
- Standalone RGB mixing: Colour values set within `MAN` section but the fixture is not in `ModE > MANU` mode.

## Fuse access

The single fuse is located on the underside panel of the fixture.

### To remove the fuse

Using a flatblade screwdriver, push down the fuse cap and then twist it anti-clockwise until it disengages from the holder.

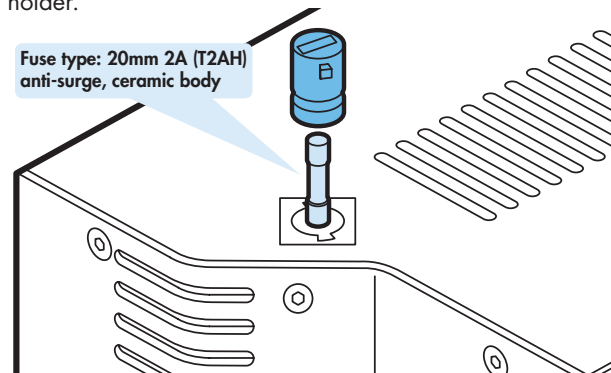

Documentation by Corporate Text & Design ([www.ctxd.com](http://www.ctxd.com))  
Release 1.01e

## Specifications

### Dimensions

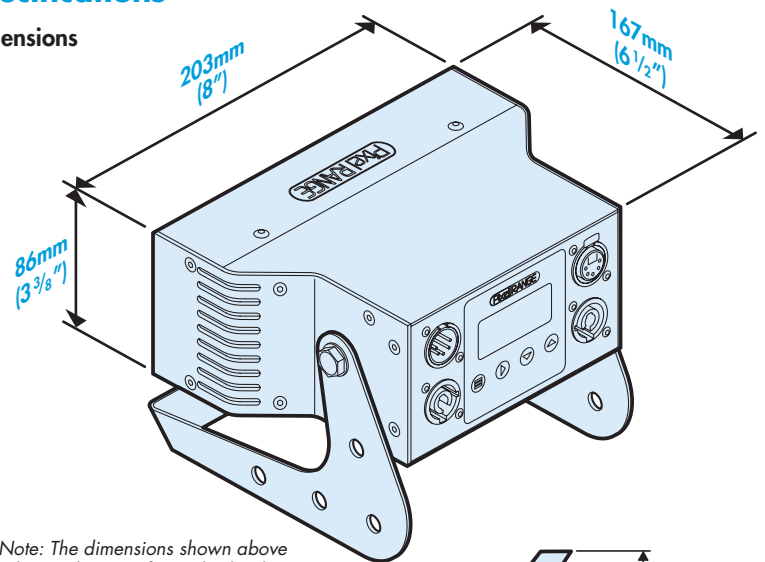

Note: The dimensions shown above relate to the main fixture body. The yoke knob extends 10mm (3/8") beyond the stated width of the fixture.

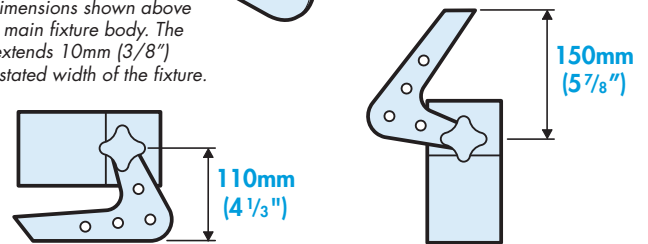

### Weight

Fixture and yoke: 2.1Kg (4.6lbs)

### Power

Input voltage: 90 to 264V AC, 47 to 63Hz autosensing

Earth leakage: 0.12mA

Connectors: Neutrik® PowerCon® (see first page for details)

Power requirements: @ 230V/50Hz @ 115V/60Hz

Standby: 2 watts 2 watts

Maximum (const.): 66 watts 66 watts

Start up (peak\*): <40 amps <20 amps

\* The peak value occurs only at first power up and lasts only for a period measured in microseconds. Adjustments may need to be made to supply circuit breakers when multiple fixtures are daisy-chained, causing them all to draw the peak simultaneously.

### Approvals

### Miscellaneous

Enclosure rating: IP20 (not protected against moisture ingress)

Control input: USITT DMX512 (input connector pin out below)



IP20 (not protected against moisture ingress)  
USITT DMX512 (input connector pin out below)

